

Growing a sustainable future

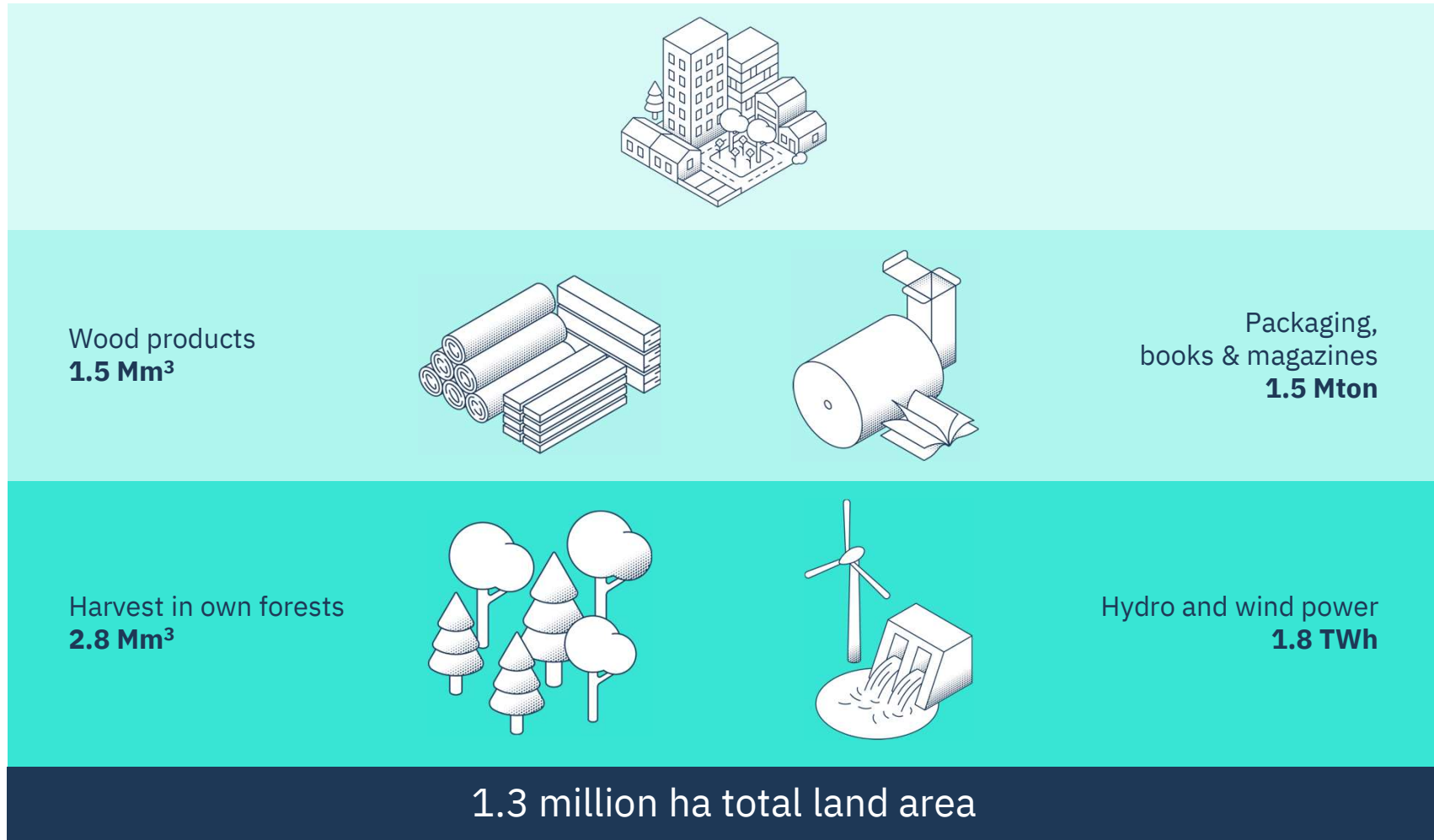

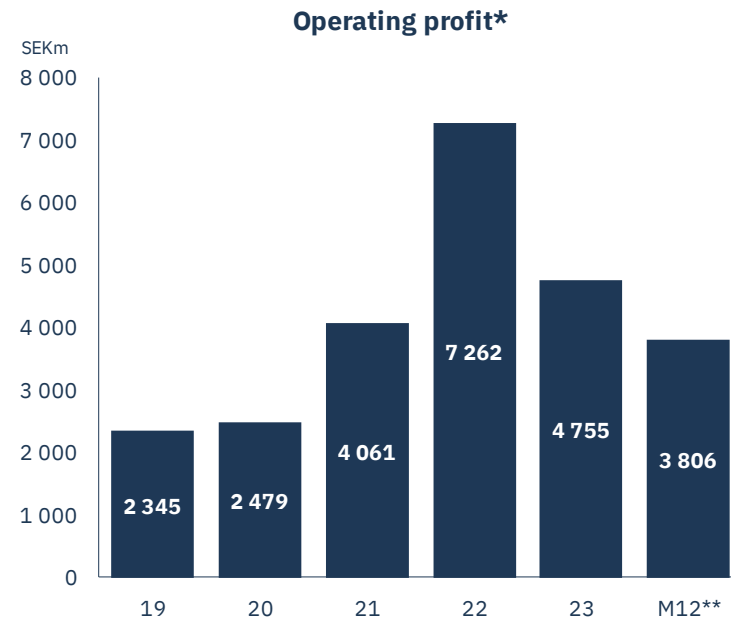

Solid earnings despite slow cycle

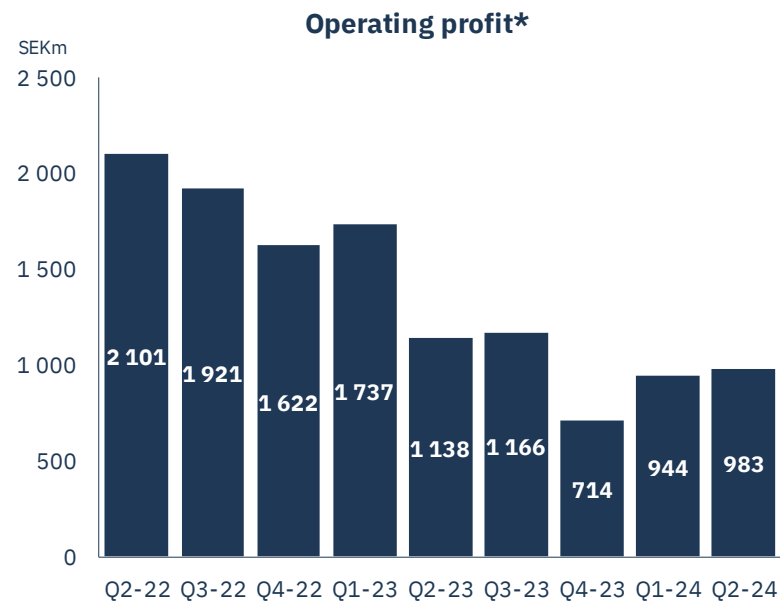

16% ROCE in our industry H1 2024

18% average for the last 10 years

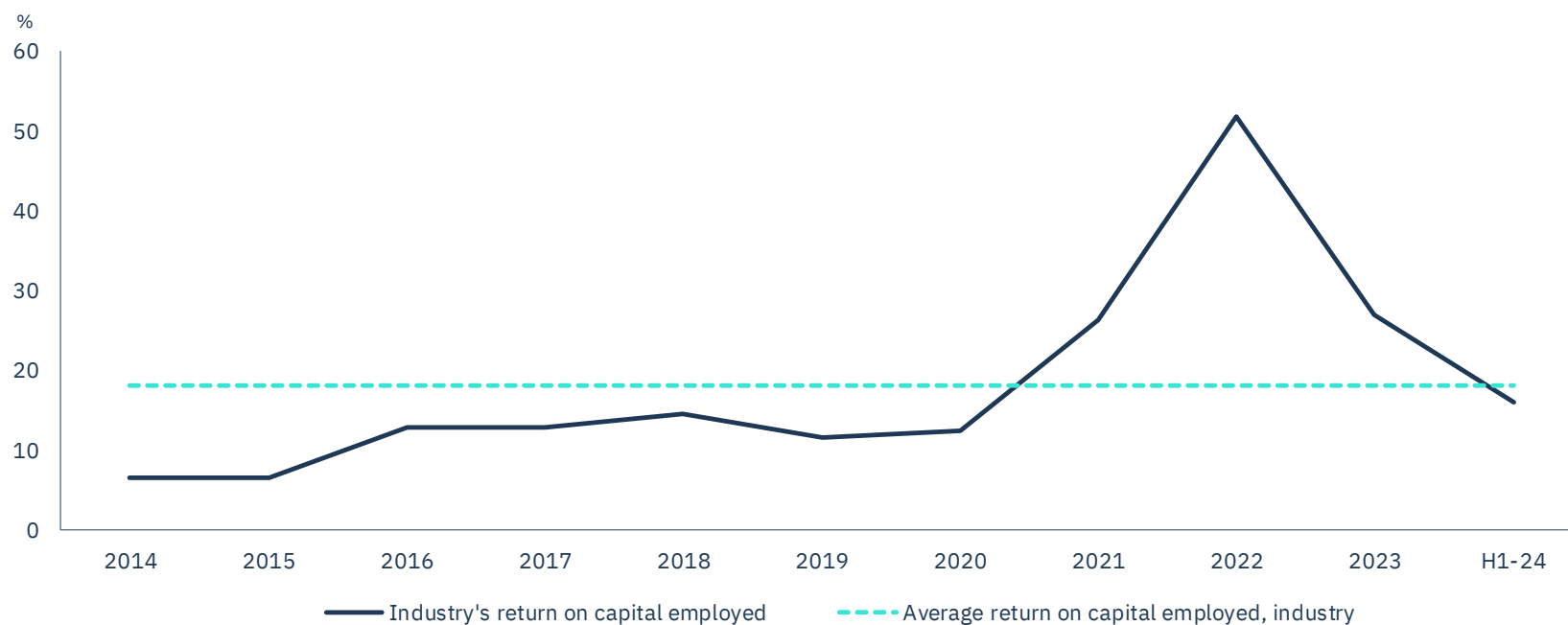

Net debt at 6% of equity

SEK 1.8 bn dividend distributed in Q2

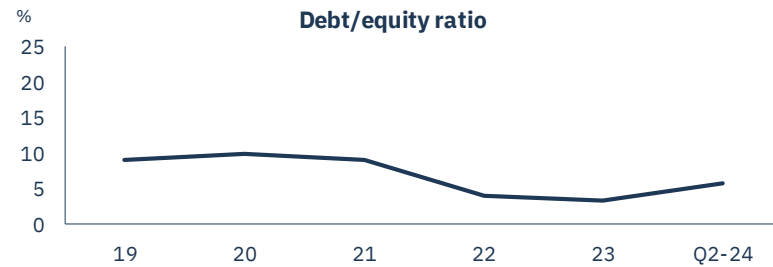
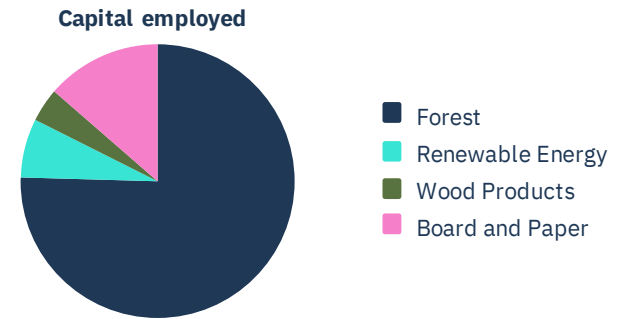
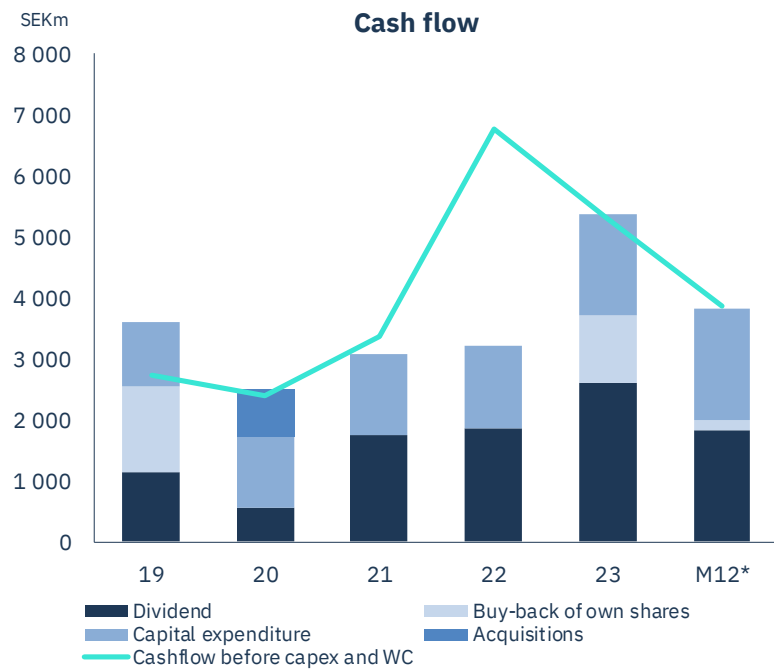

Expanding wood products and wind power

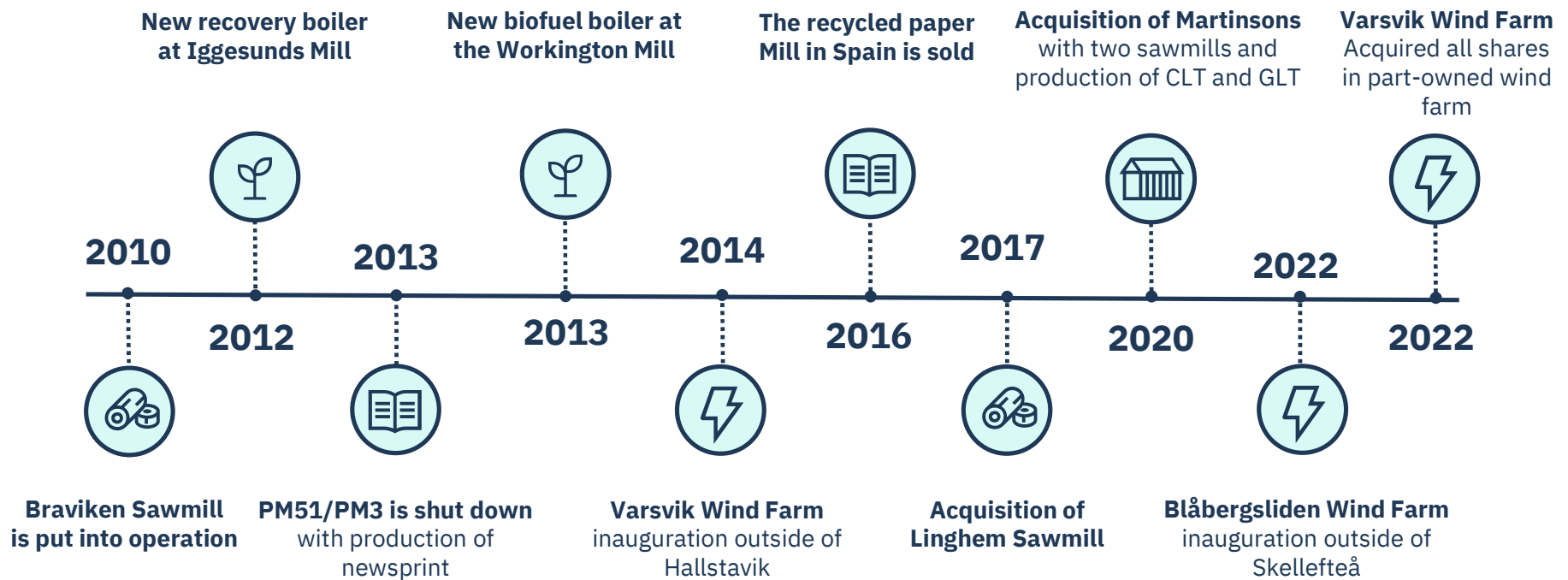

A bet on the green transition

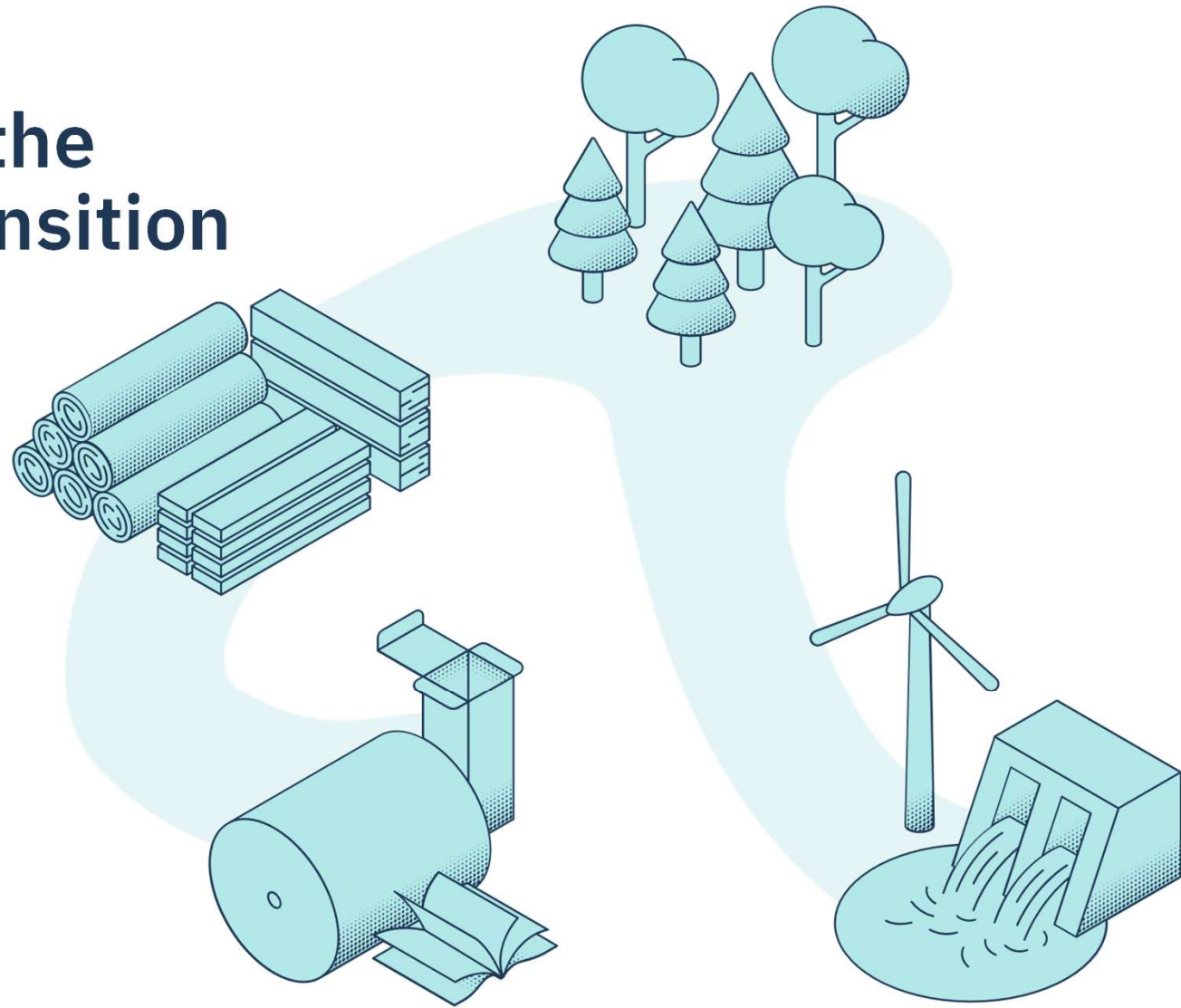

The world is fossil fueled

Fossil energy has quadrupled last 50 years

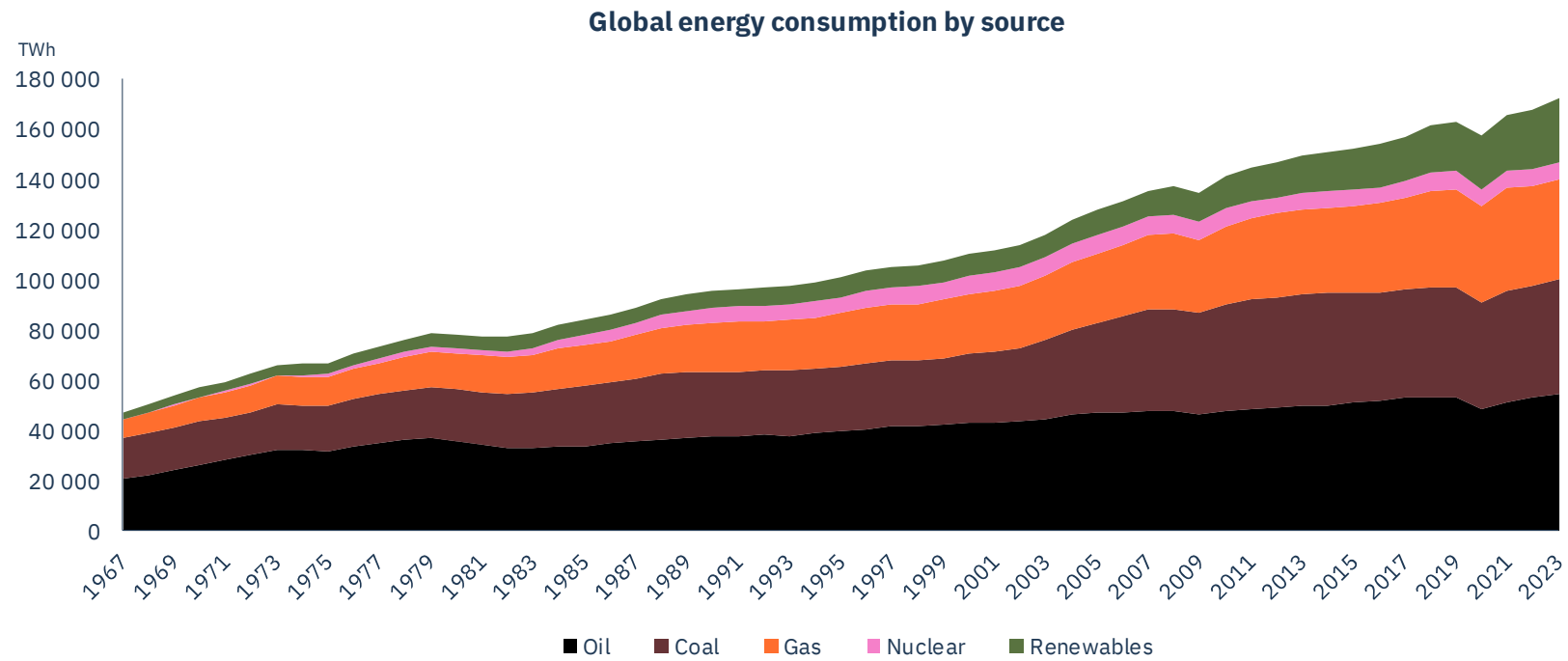

EU has high ambitions for climate & ecosystems



European industry has not decarbonised

Biodiversity is under pressure

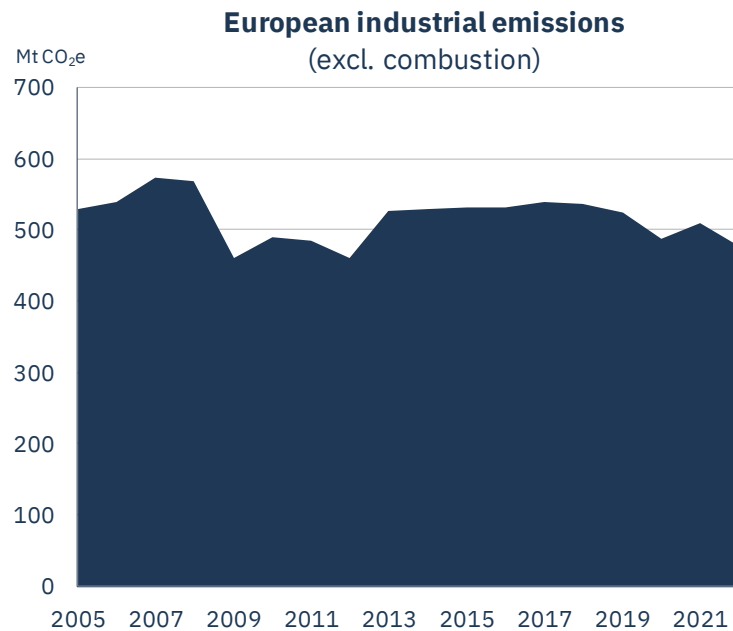

Source: European Environment Agency

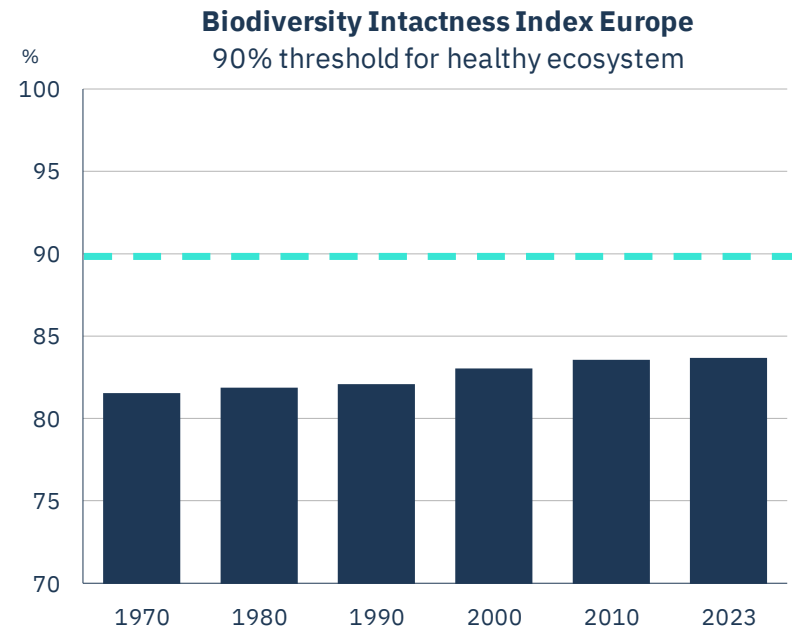

Source: [Natural History Museum](#)

We have lowered our fossil emissions by 90%

Swedish ecosystems are in balance

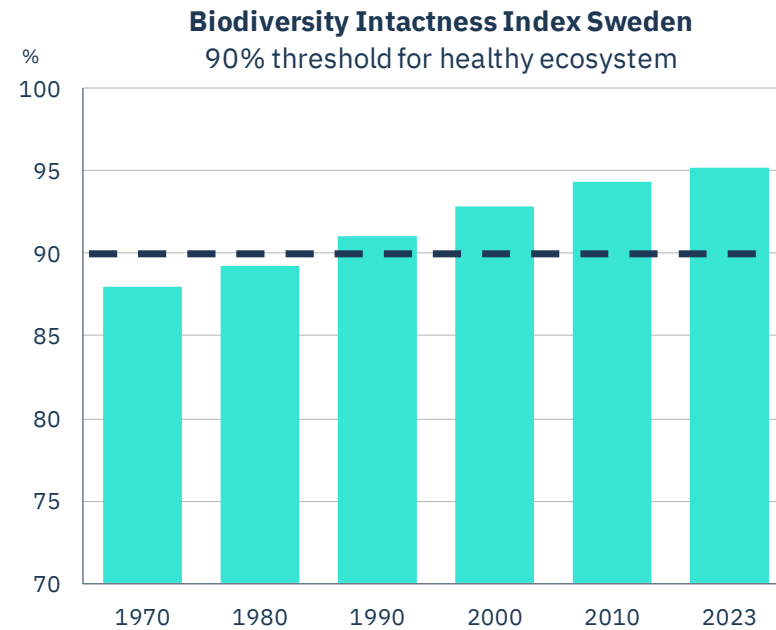
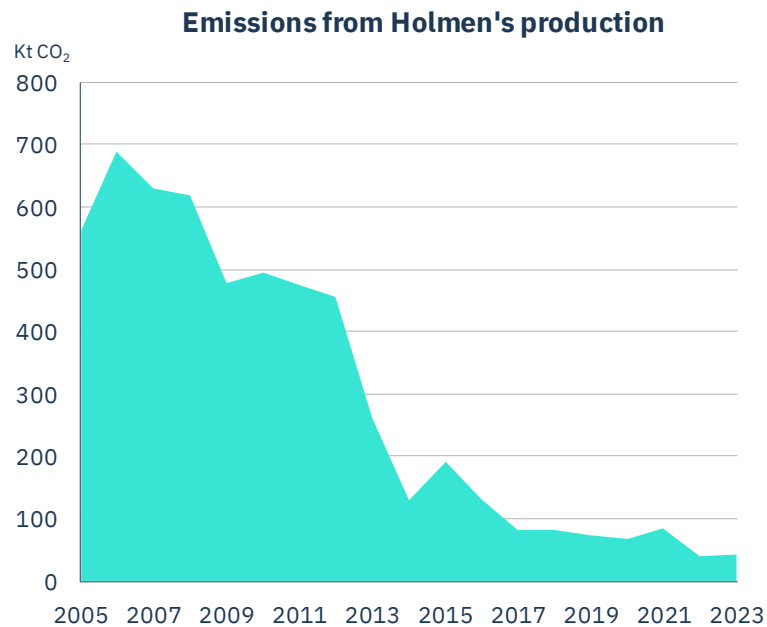

Access to wood & fossil-free energy

Forest assets*

- >65
- 51-65
- 31-50
- 11-30

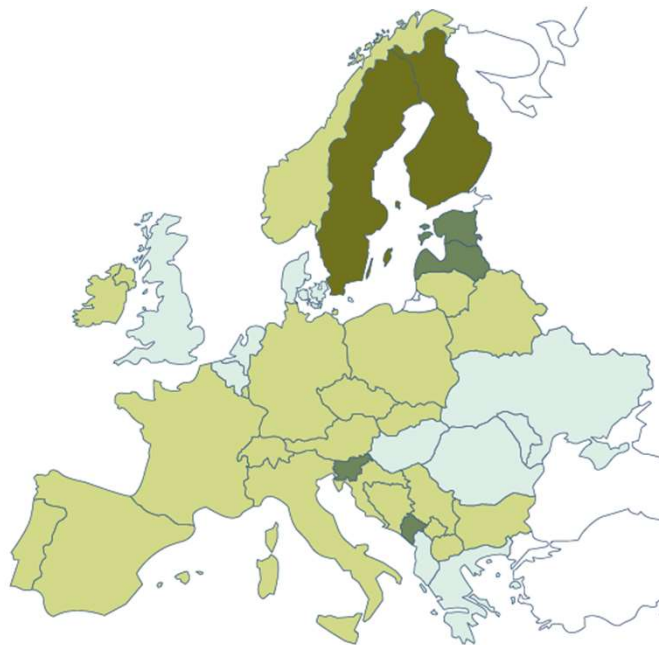

Carbon intensity from electricity production**

- <100
- 101-200
- 201-300
- 301-500
- >500
- No data

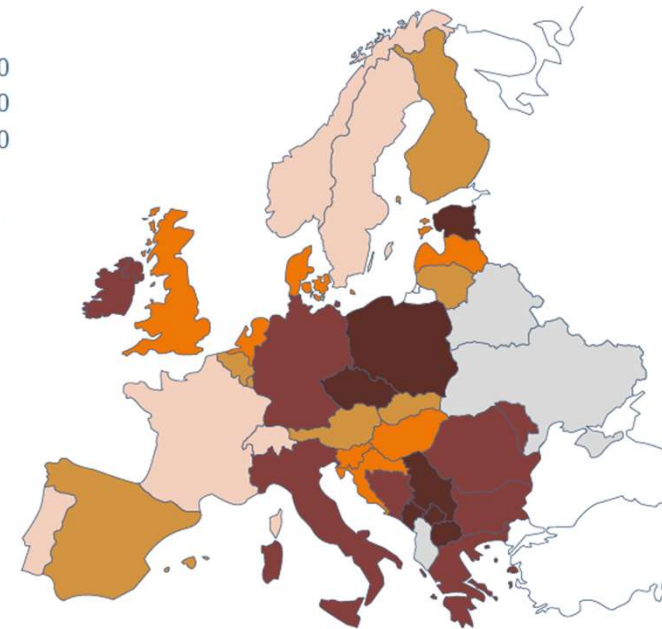

Clean air and plenty of water in the Nordics

Air pollution*

- <8
- 8-9
- 10-11
- 12-14
- >14
- No data

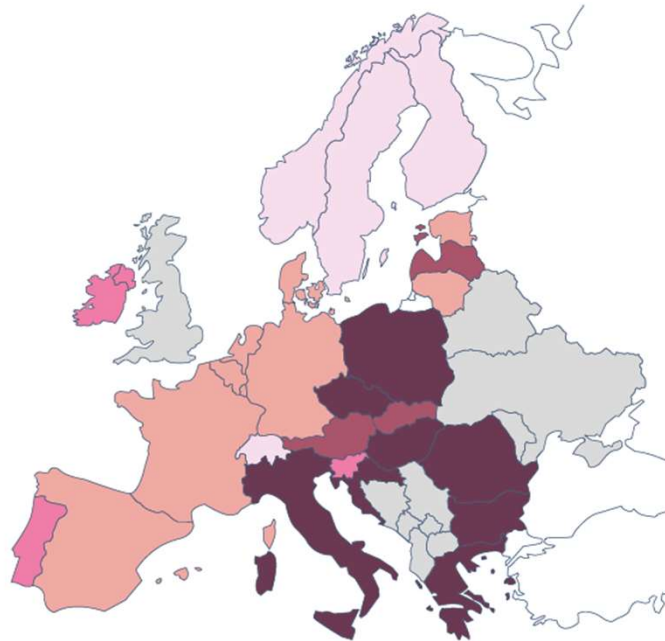

Water stress**

- Low
- Low-medium
- Medium-high
- High
- Extremely high
- No data

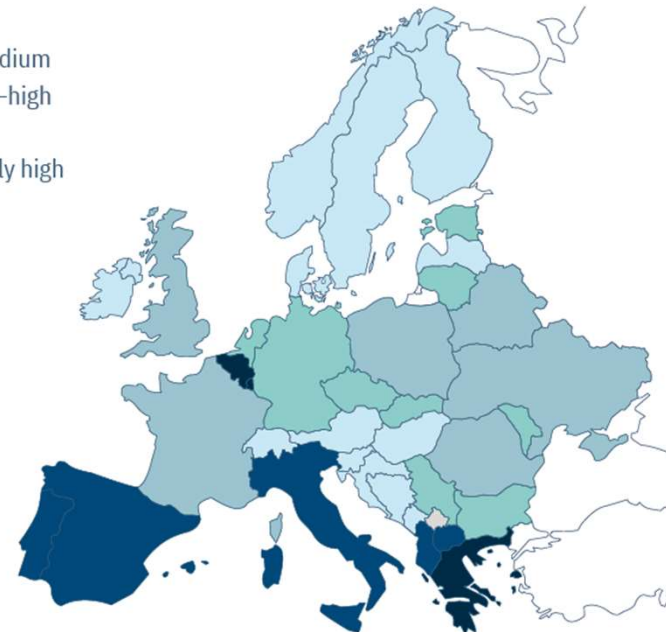

We're beyond net zero

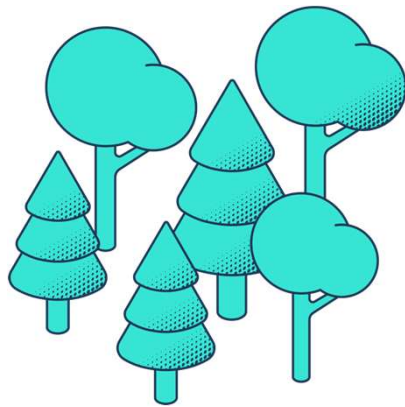

1.6 Mt CO₂
Net increase in growing forest

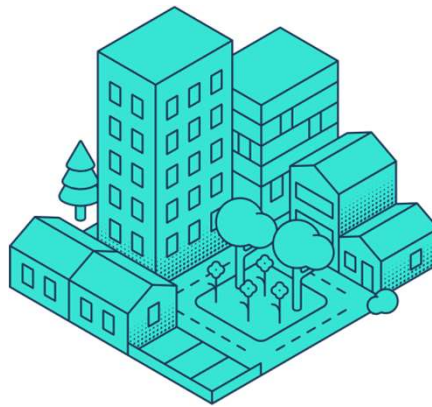

0.5 Mt CO₂
Net storage in buildings

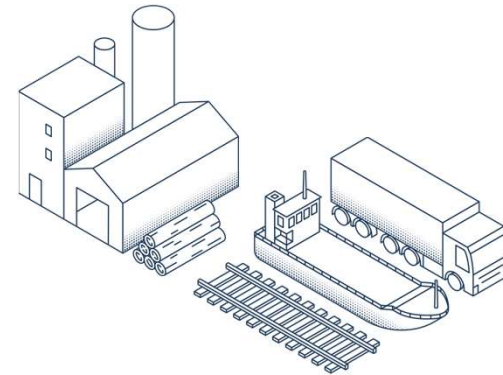

-0.1 Mt CO₂e Scope 1+2
-0.6 Mt CO₂e Scope 3

H

Board and Paper

1.5 million tonnes per year

Helping our customers with their CO2 footprint

Consumer board, transport packaging, books & magazines

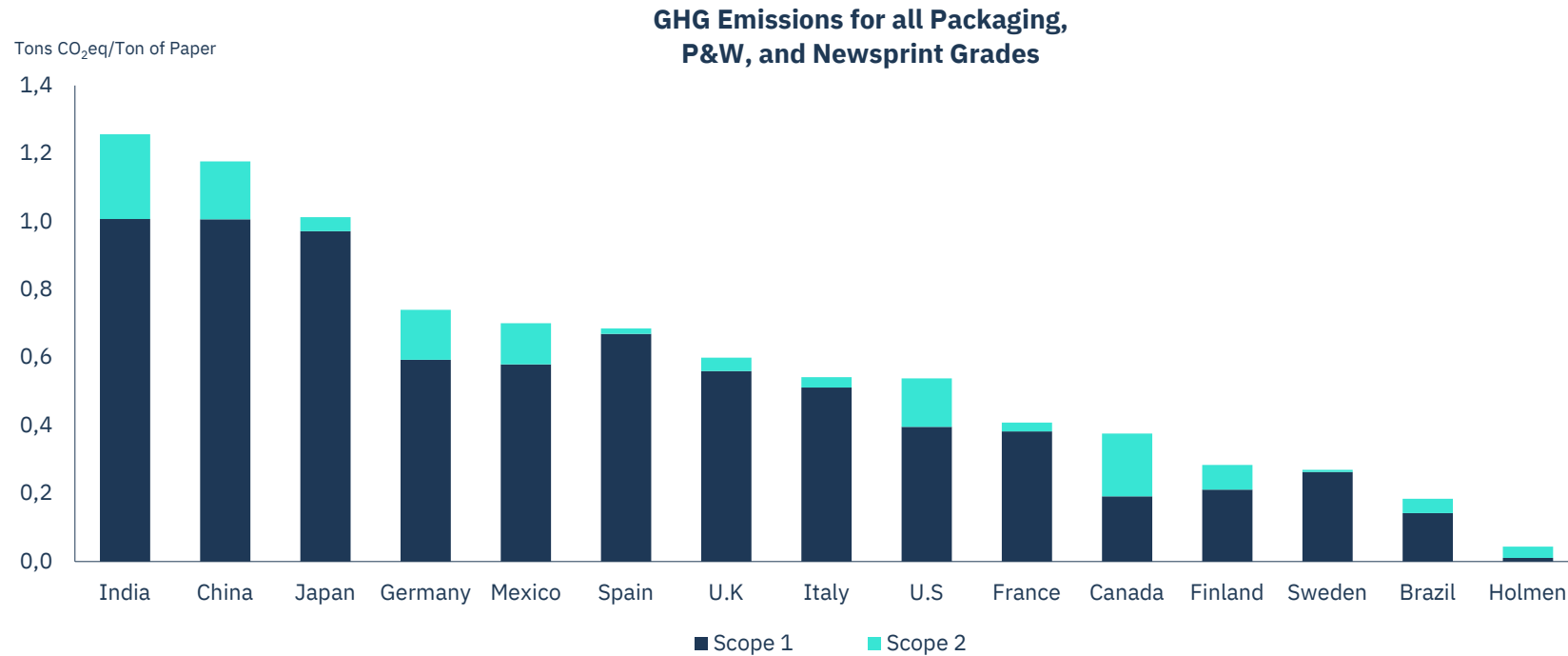

Investing to enter transport packaging

While strengthening the book offering

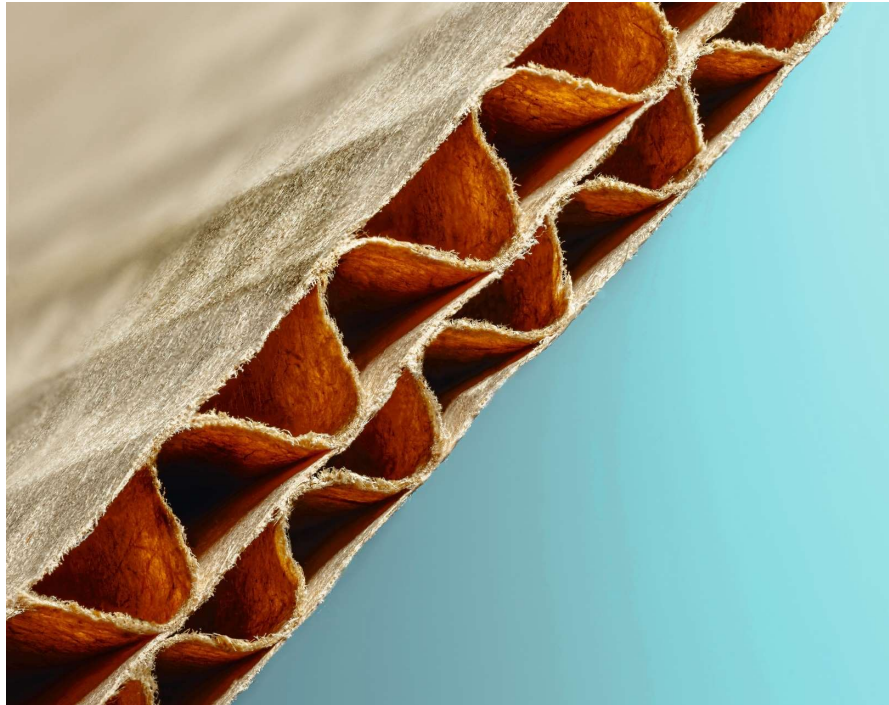

Board market gradually recovering

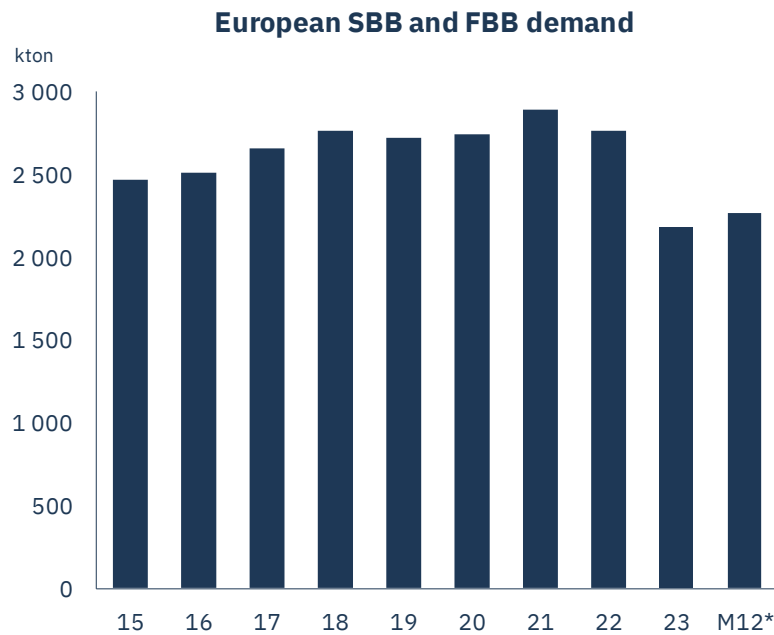

*Q3-23 – Q2-24
 **Adjusted for rebates
 Source: CEPI and Fastmarkets RISI

Stable paper market

Supported by increasing fibre costs

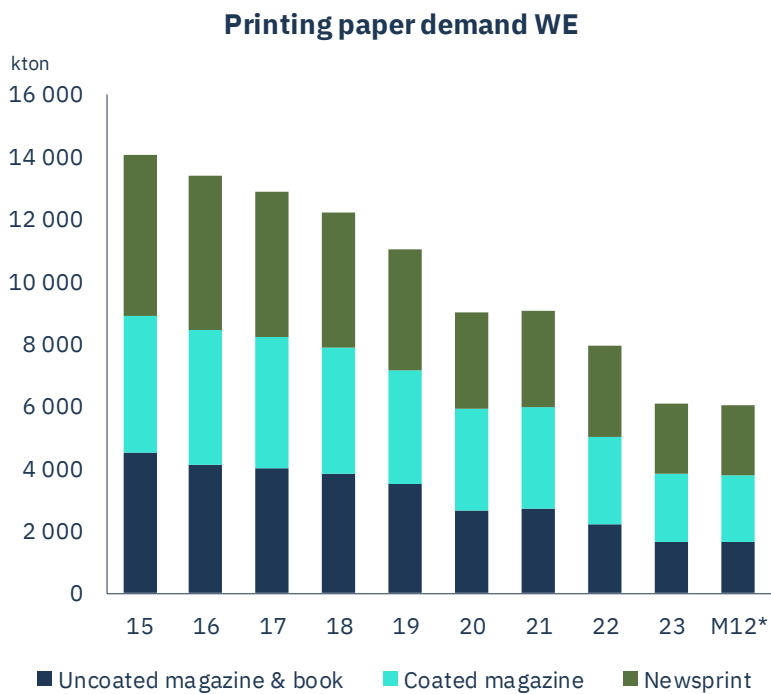

*Jun 2023 – May 2024
 **Adjusted for rebates.
 Source: Euro Graph, Fastmarkets RISI

Solid ROCE over time

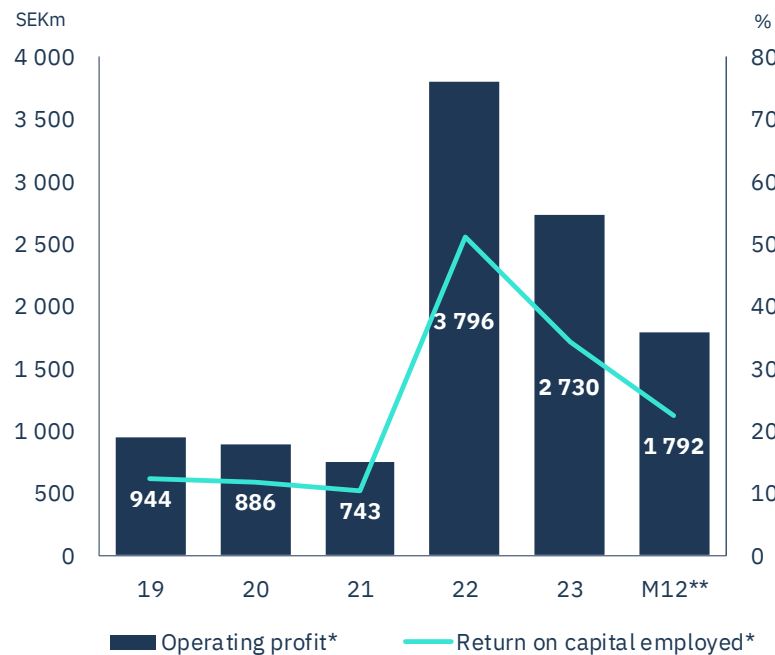
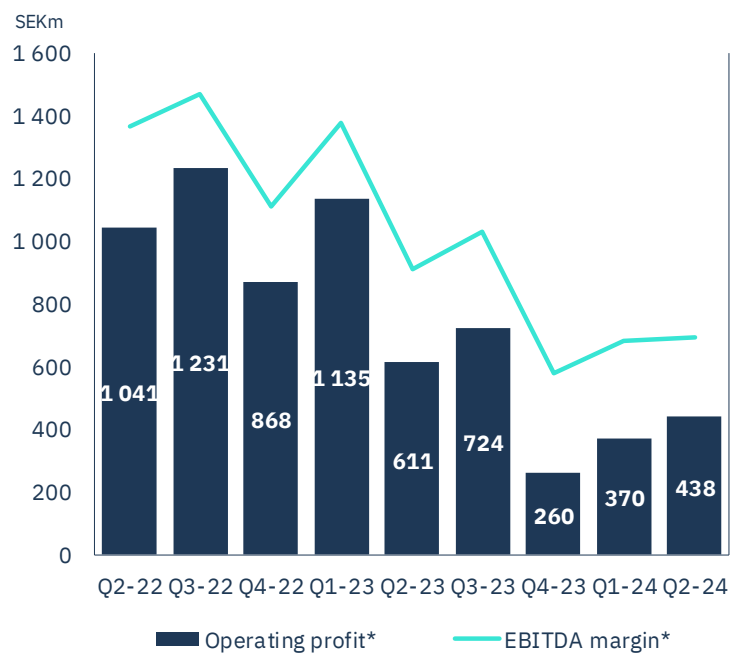

*Excl items affecting comparability.
 **Q3-23 – Q2-24

H

Wood Products

1.5 million m³ per year

Offer a green alternative to concrete & steel

CBAM will push up the cost for building materials

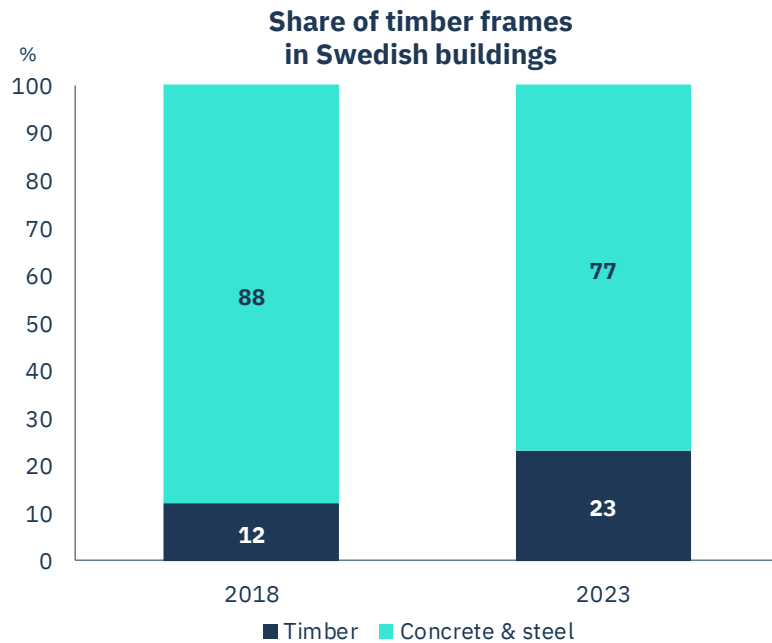

Developing our asset base with targeted Capex

- Finalising upgrade of Iggesund Sawmill
- Establishing a logistic hub at Braviken for GLT
- Ramping up CLT production after removing bottle-neck

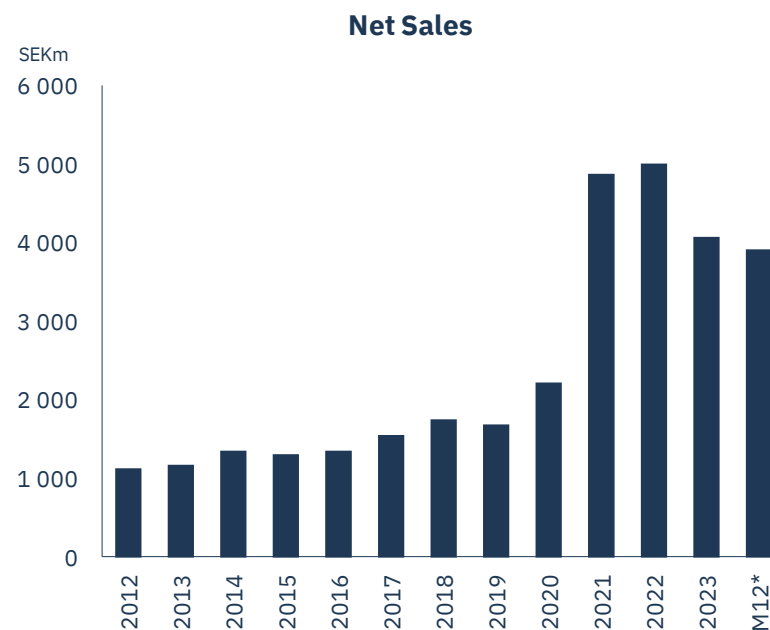

Slow constructional cycle

Price increase driven by seasonal uptick in demand

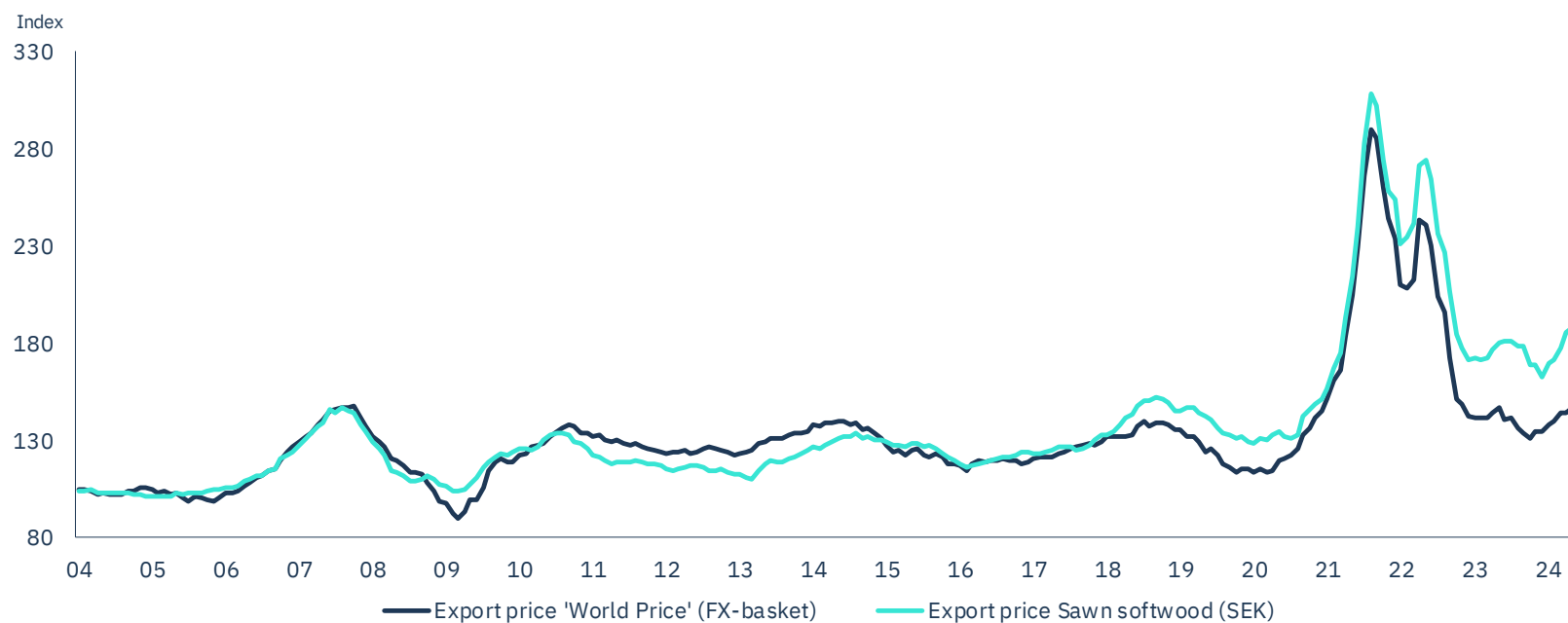

Margin under pressure from high log costs

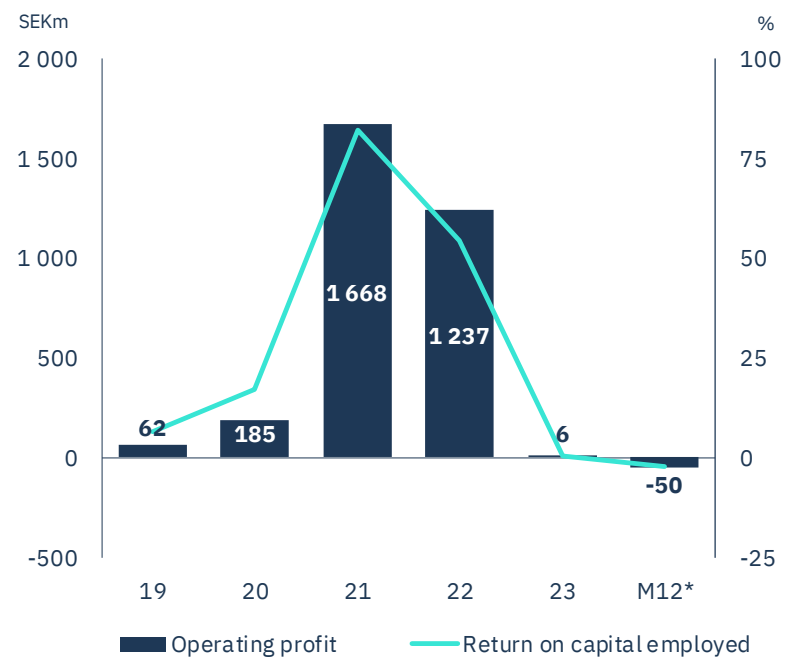
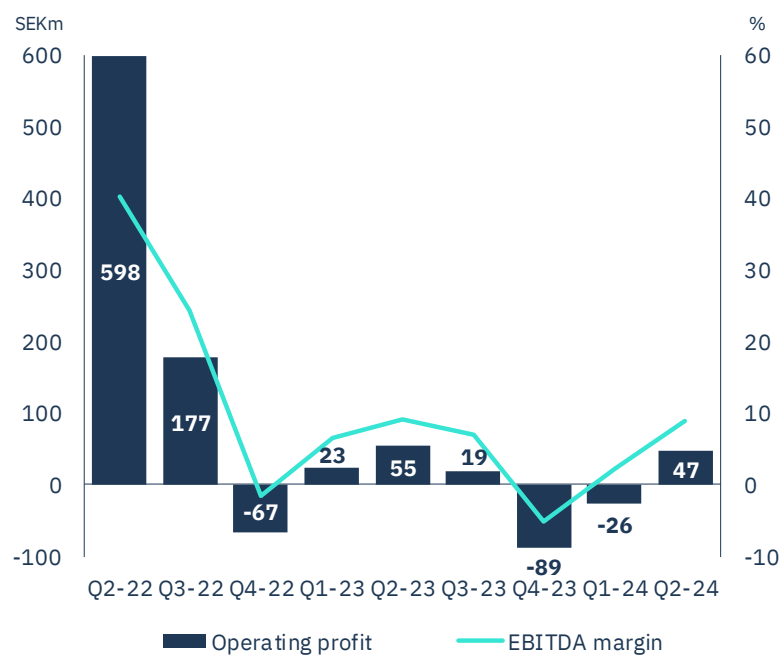

H

Renewable Energy

1.8 TWh per year



Supporting the emerging green industry

Blisterliden will grow our renewable production another 20%

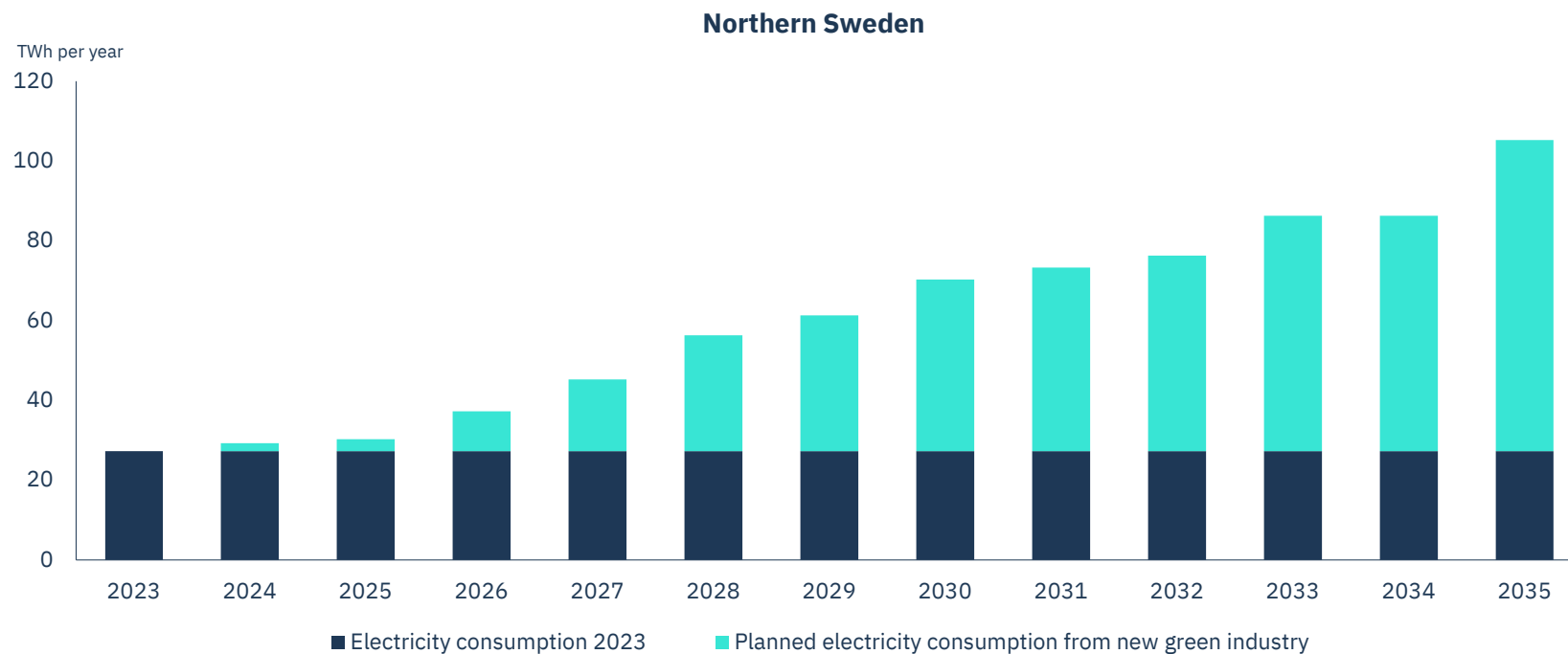

Developing a wind farm portfolio

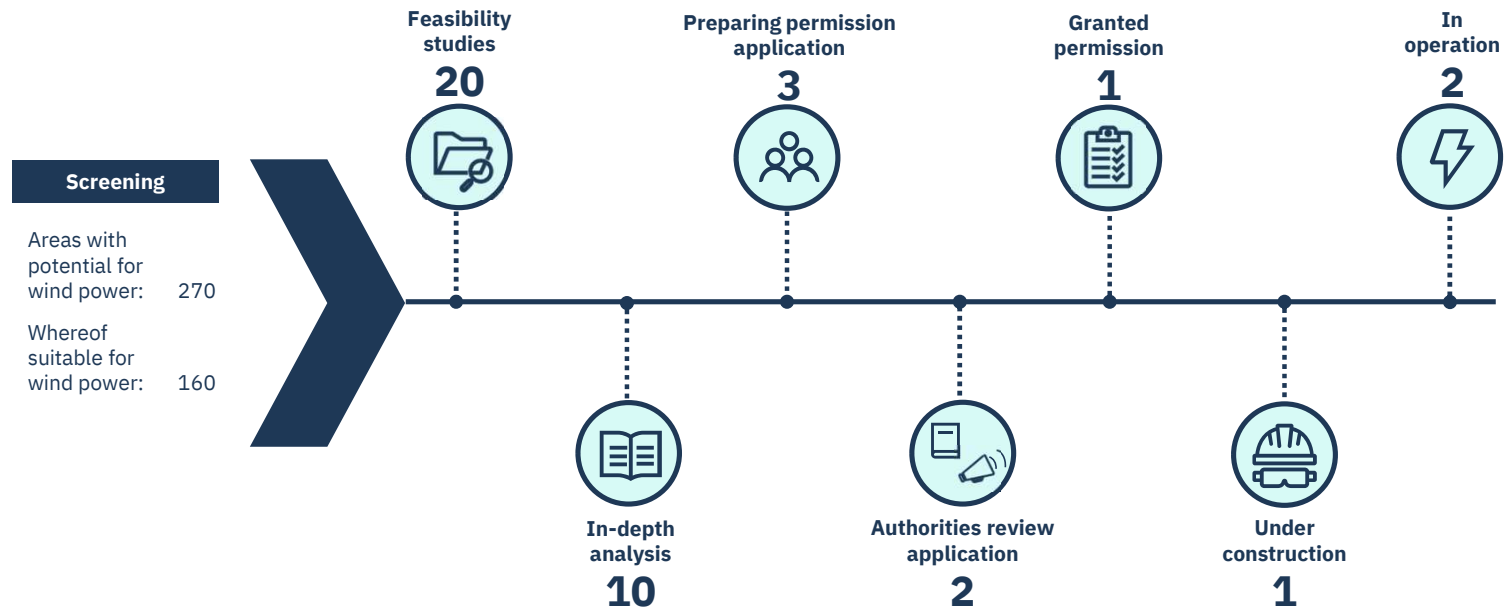

Spread vs Germany widened again in Q2

Nordic prices 20% below normal levels for a Q2

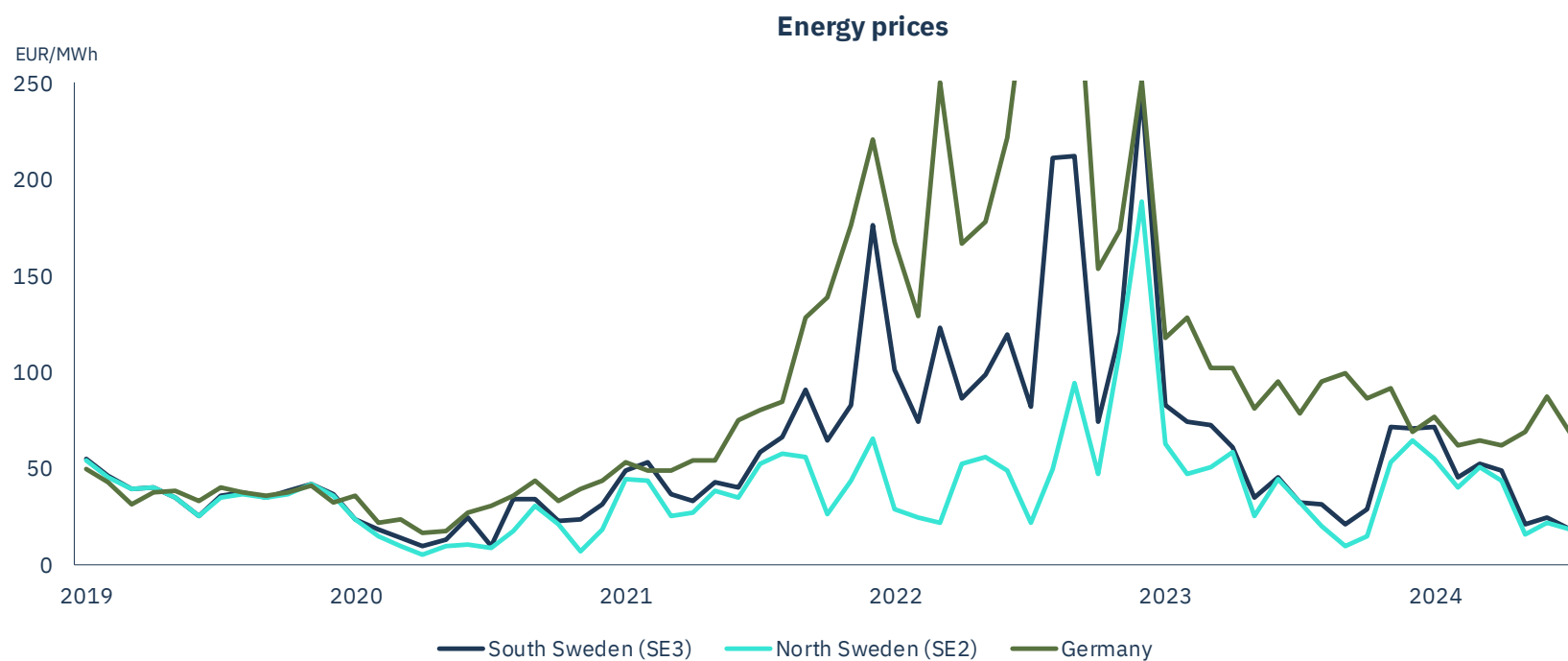

30% premium to market price

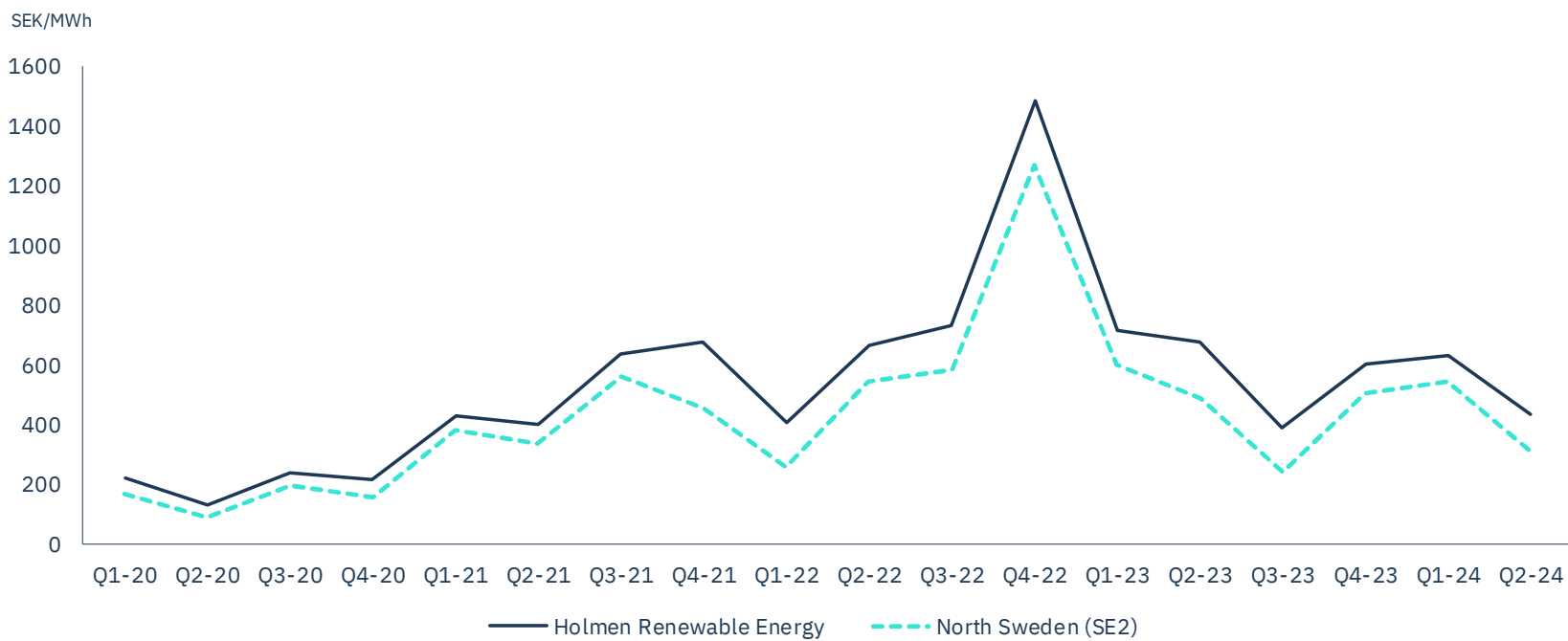

Low prices & production in Q2

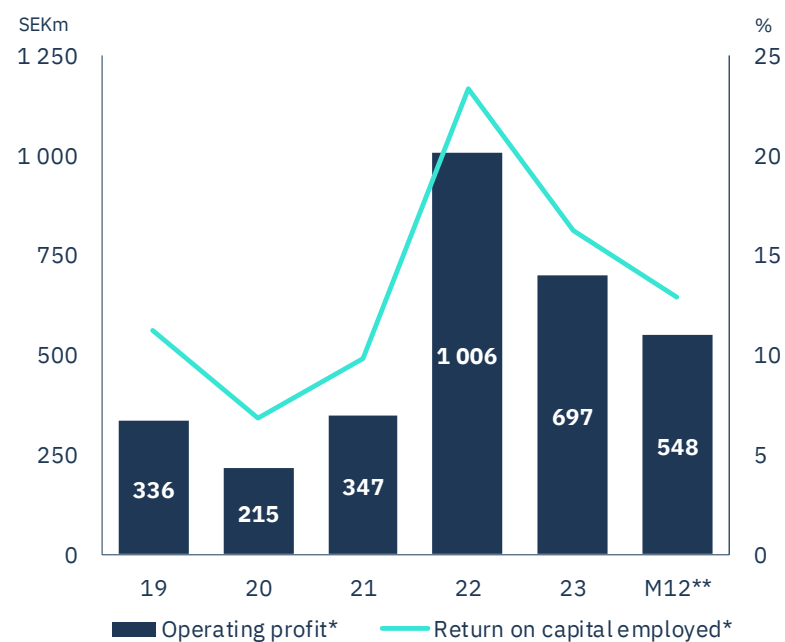
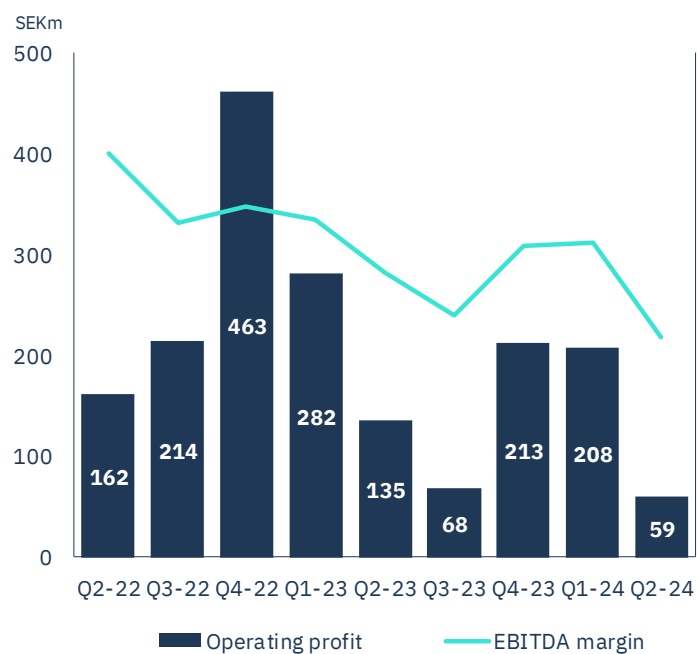

*Excl item affecting comparability.
 **Q3-23 - Q2-24

Forest

1.3 million ha total land area

1.0 million ha productive forest land



Real price increase of 1,6% p.a. last 20 years

Standing timber volume has grown by 0,6% per year

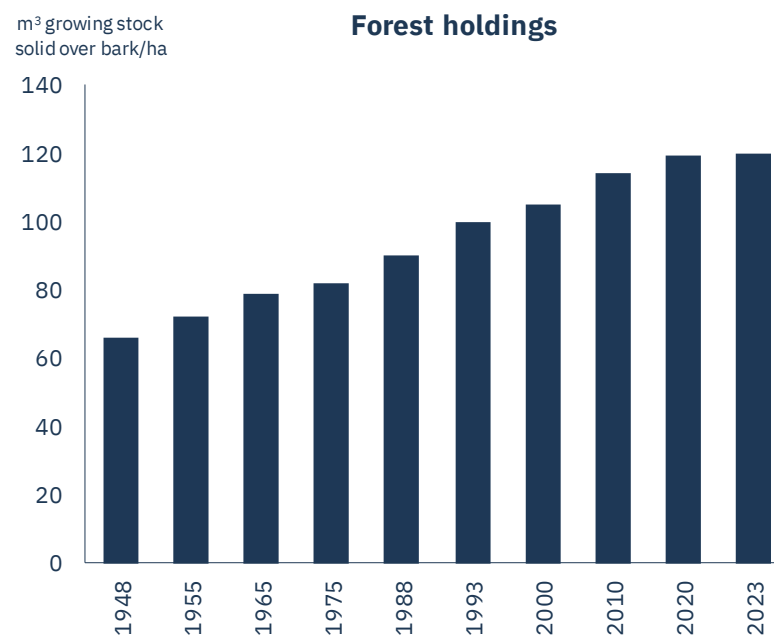
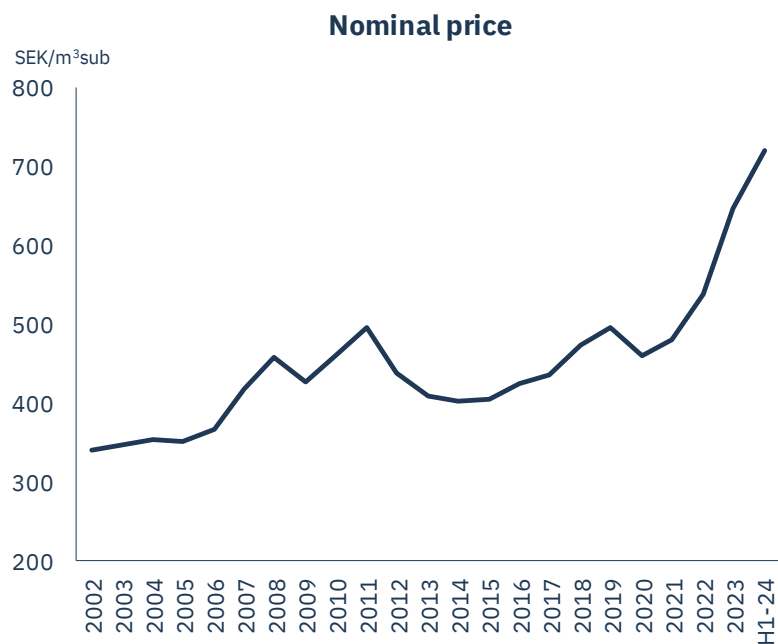

Growing forests with increased biodiversity

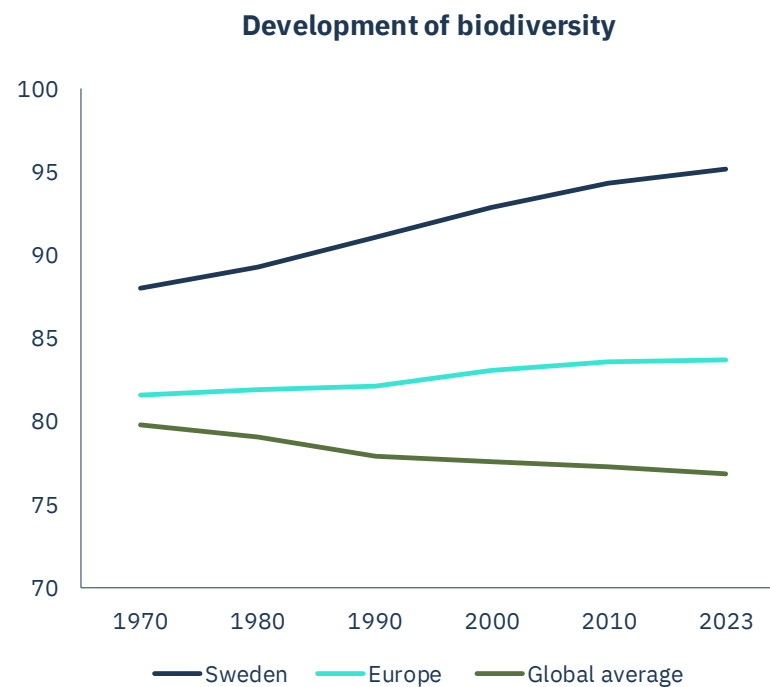
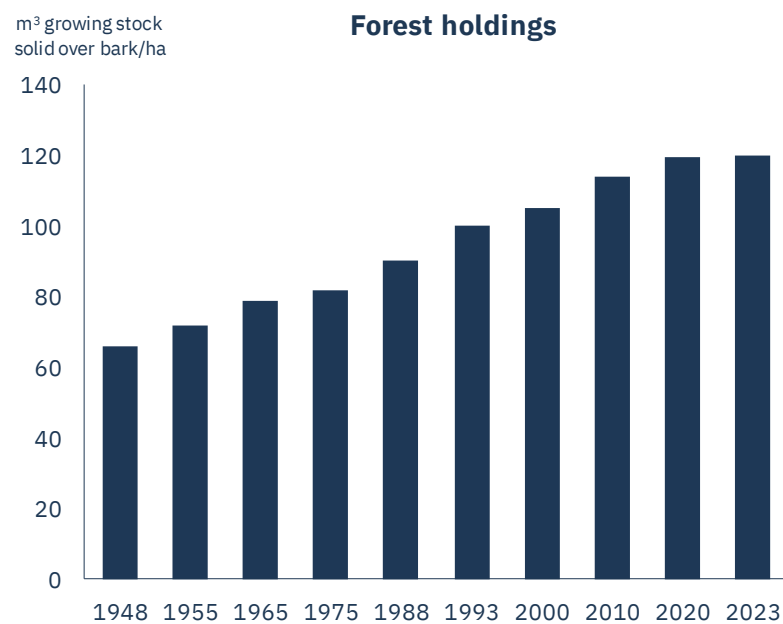

Still good mark-up on wood for pulp

Normal relationship between sawn wood & net log cost

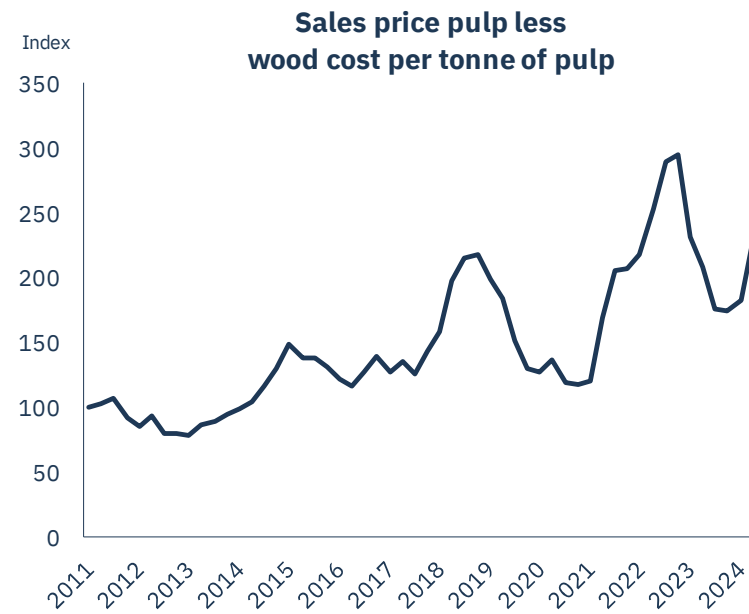

Harvesting cash-flow has increased 60% in 3 years

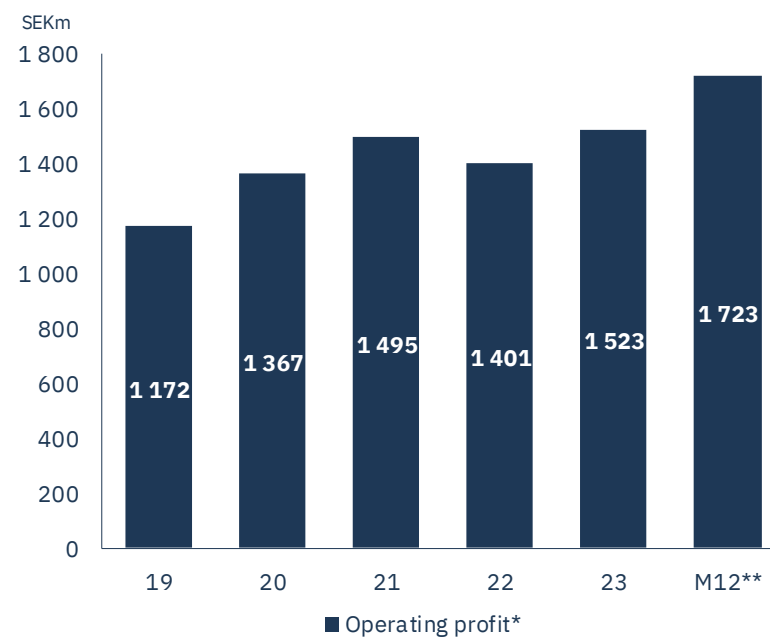
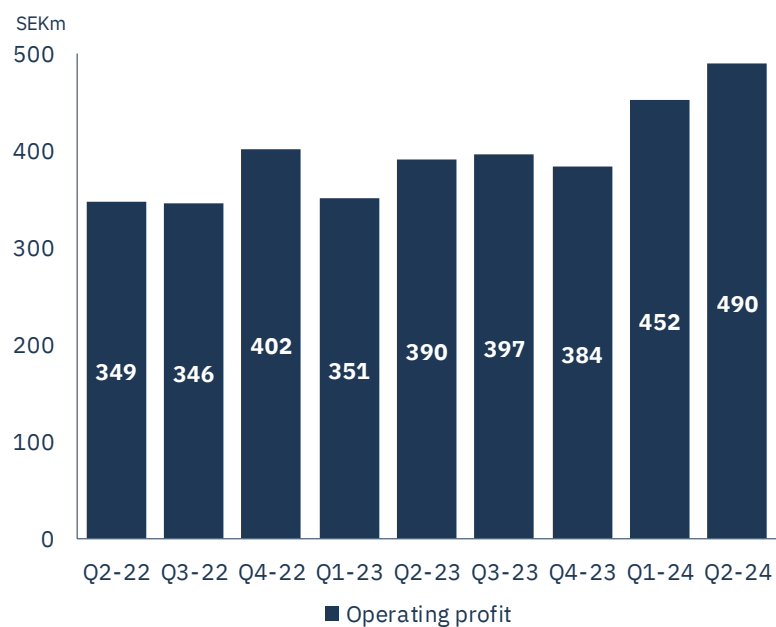

A photograph of a forest with a large, textured tree trunk in the foreground on the left. The background is filled with many other trees, some of which are blurred, creating a sense of depth. The ground is covered with green grass and moss. The text "Growing a sustainable future" is overlaid in the center in a light blue, sans-serif font.

Growing a sustainable future

We grow houses

Leftovers are converted into renewable packaging and paper
We harvest the energy that blows and runs through our forests

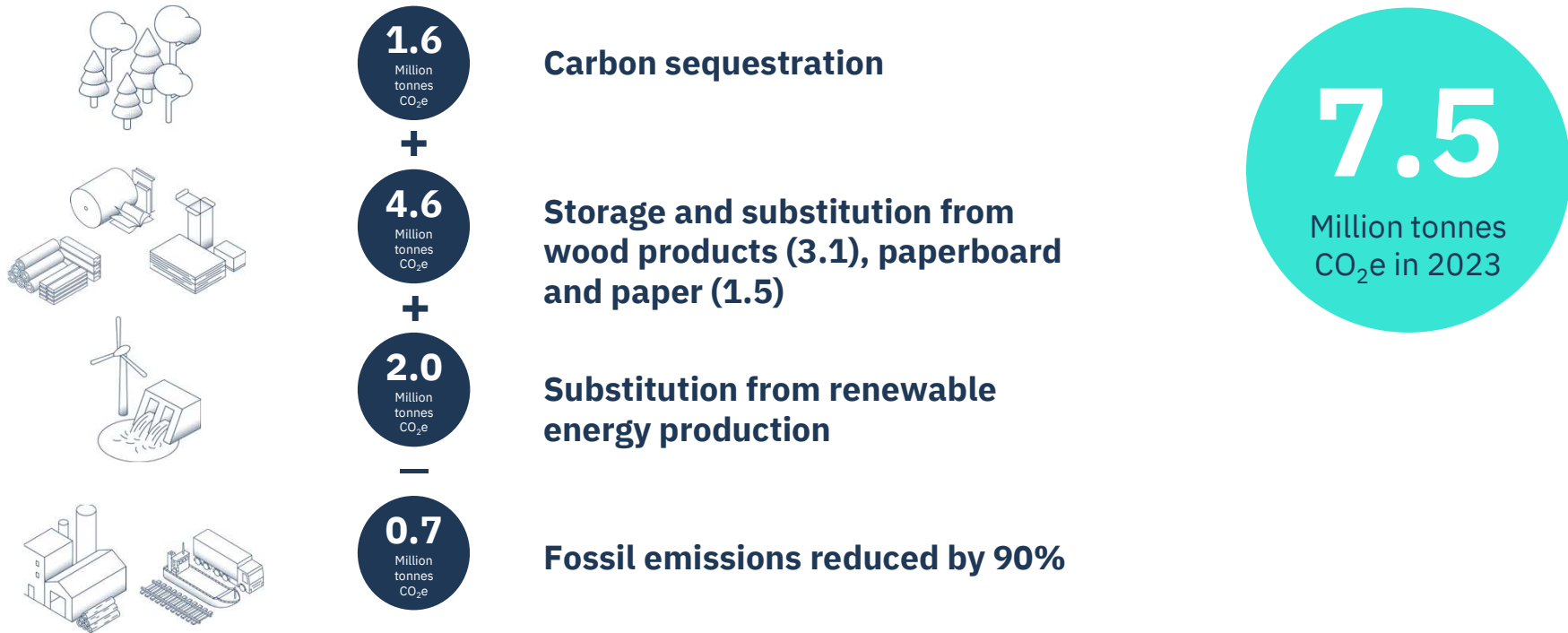

Increasing our contribution to the climate

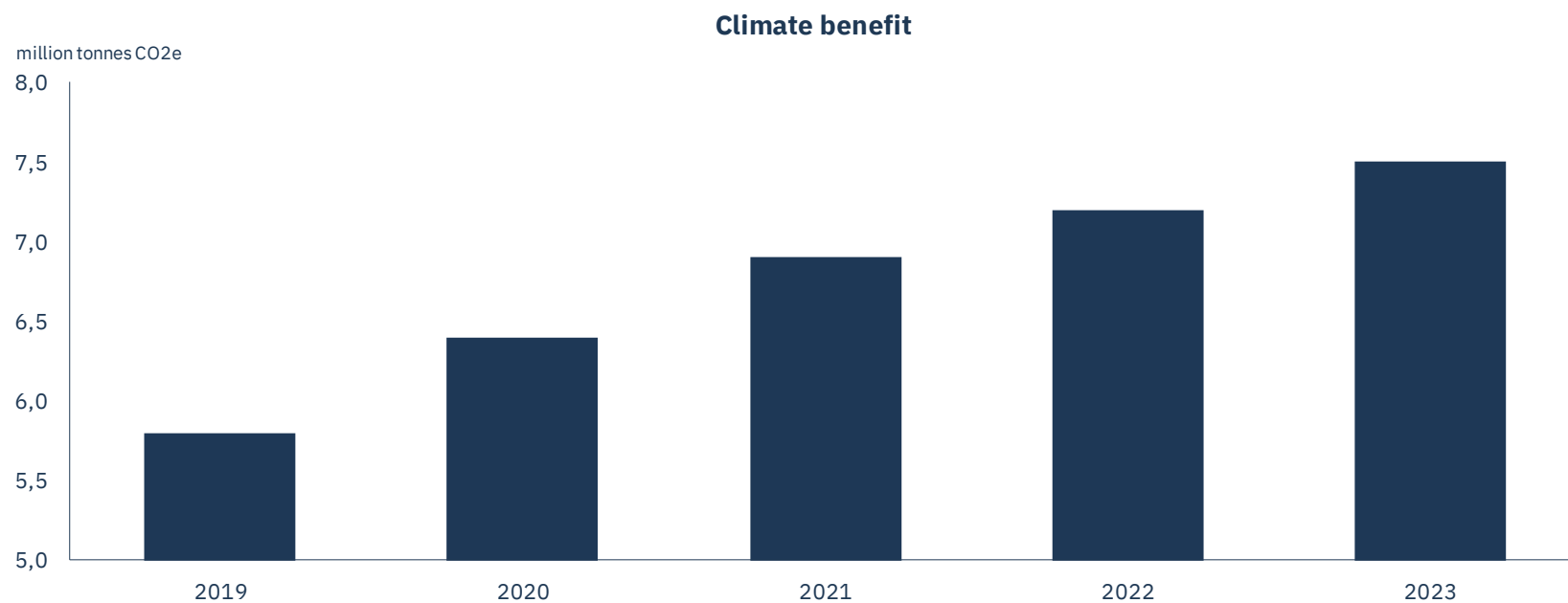

HOLMEN

holmen.com